

INTRODUCTION

Please read this Instruction Booklet thoroughly to obtain the greatest benefit from your new Philips turntable.

DESIGNATION OF PARTS

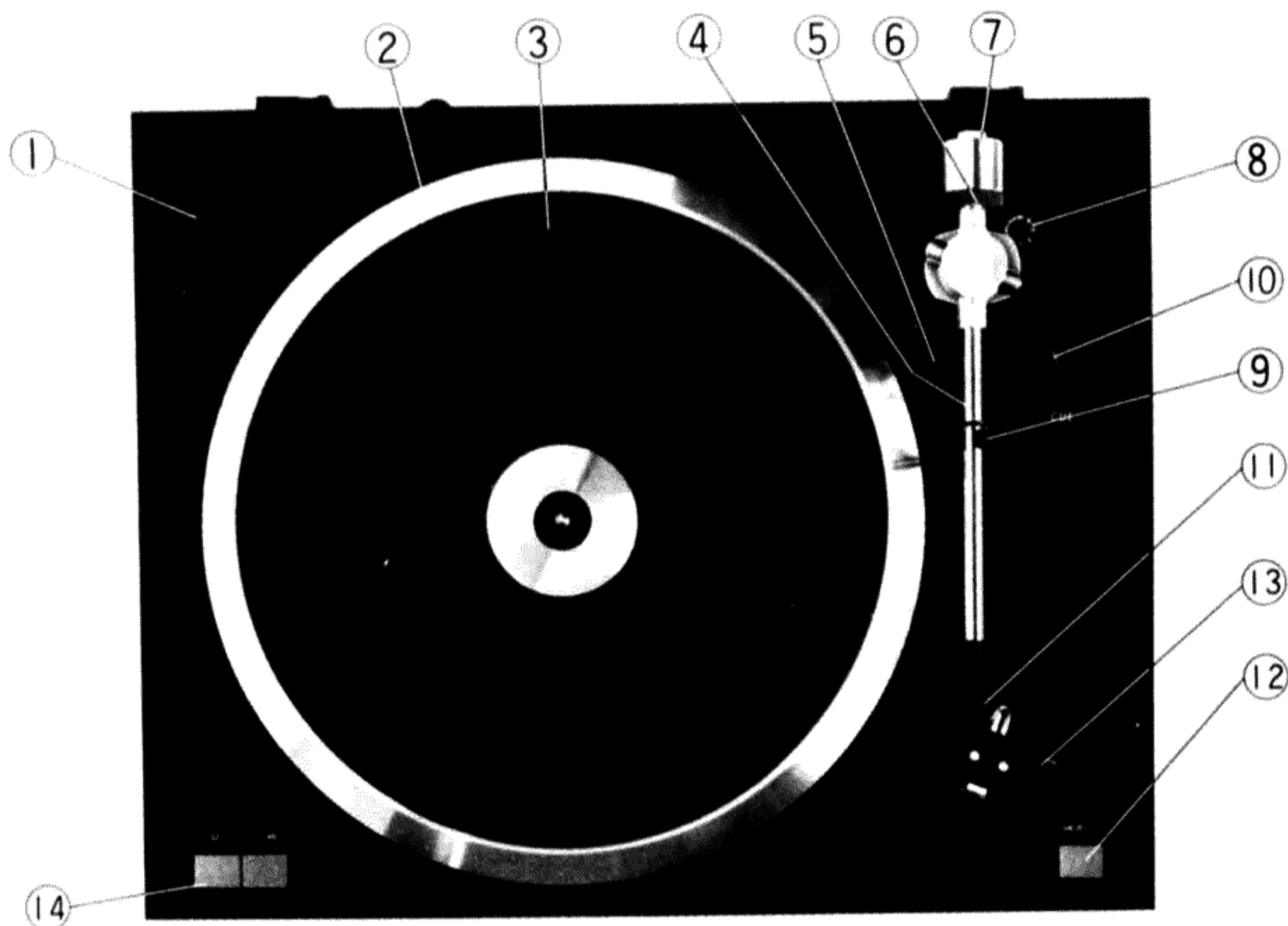

Fig. 1

- | | |
|-------------------------|----------------------|
| 1. 45 rpm disc adaptor | 9. Arm rest and lock |
| 2. Platter | 10. Cueing lever |
| 3. Turntable mat | 11. Head shell |
| 4. Tone-arm | 12. Reject button |
| 5. Automatic arm lift | 13. Manual arm lift |
| 6. Counter weight dial. | 14. Speed Selector |
| 7. Counter weight | |
| 8. Anti-skate control | |

BEFORE ASSEMBLY

1. Carefully separate all components of your turntable from the packaging.
2. Before disposing of any packaging material check that all the following items are present.

This step avoids any possibility of discarding part of your turntable with the unwanted packaging material:—

- (a) Dust cover
- (b) Turntable mat
- (c) Counterweight
- (d) Headshell.

OPERATION

1. Release the tone-arm from its clamp.
2. Move the cueing lever to the "∇" position.
3. Slide the tone-arm towards the record causing the turntable to start revolving automatically.
position the stylus over the start of the desired track.
4. Select the required record speed ($33\frac{1}{3}$ or 45 R.P.M.) using the speed selector control. The speed must only be changed while the turntable is revolving otherwise the drive belt may be damaged.
5. Lower the cueing lever to the "∇" position thus causing the arm to lower gently onto the record's surface.
6. When the tone-arm reaches the end of the recording it will automatically return to the arm rest and the turntable will be switched off.
7. Press the reject button if it is desired to terminate playing before the tone-arm reaches the end of the record. The turntable will turn off in the same manner as in (6) above.

PRECAUTIONS

1. Never impede the tone-arm while it is automatically returning to its rest position as serious damage may result.
2. When moving the tone-arm manually never force it beyond either its inner or outer limit of travel.
3. To avoid possible damage to both record and stylus, the cueing lever should be used at all times to raise or lower the stylus onto the record surface.
4. Always change the record speed while the turntable is revolving to avoid drive belt damage.
5. Always reinsert the transport screws when transporting the turntable in addition always engage the tone-arm clamp during transportation.
6. Never leave the stylus on the record surface while the turntable is stationary.

SPECIFICATIONS

Type	Belt drive auto-return system with cueing.
Turntable speeds	33 1/3 rpm and 45 rpm
Motor	Four pole synchronous motor
Turntable platter	310mm, Aluminium Diecast
Tonearm	Static balanced, straight tonearm with direct readout stylus pressure and anti-skating control.
Effective arm length	213mm
Wow and Flutter	0.1%
Signal/Noise Ratio	45 dB
Power Requirements	240 V.A.C. 50 Hz
Dimensions	440(W) x 350(D) x 130(H) mm
Power consumption	10 W
Weight	(net) 5 kg
Weight with packing	(Gross) 6.7 kg

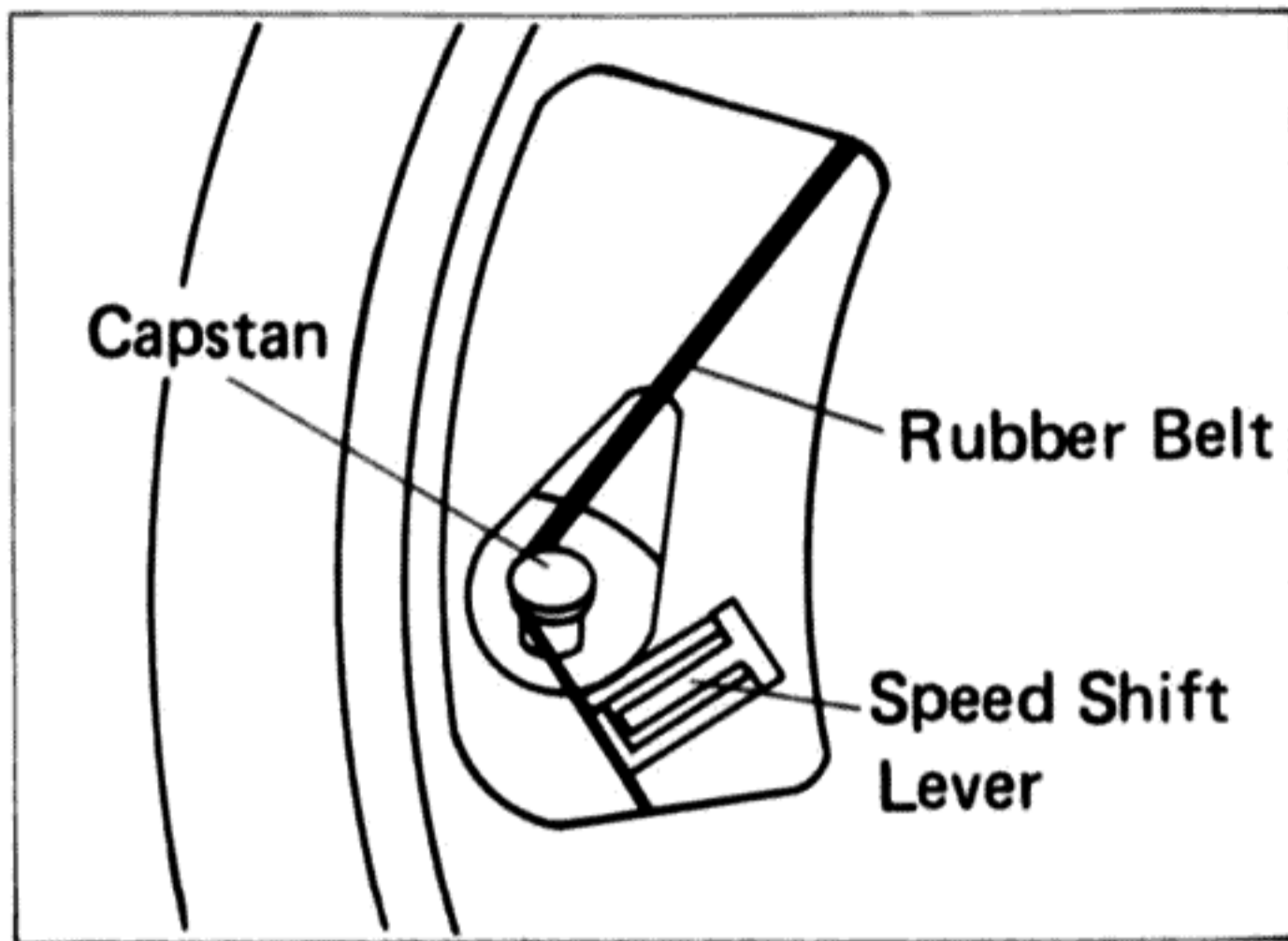

Fig. 2

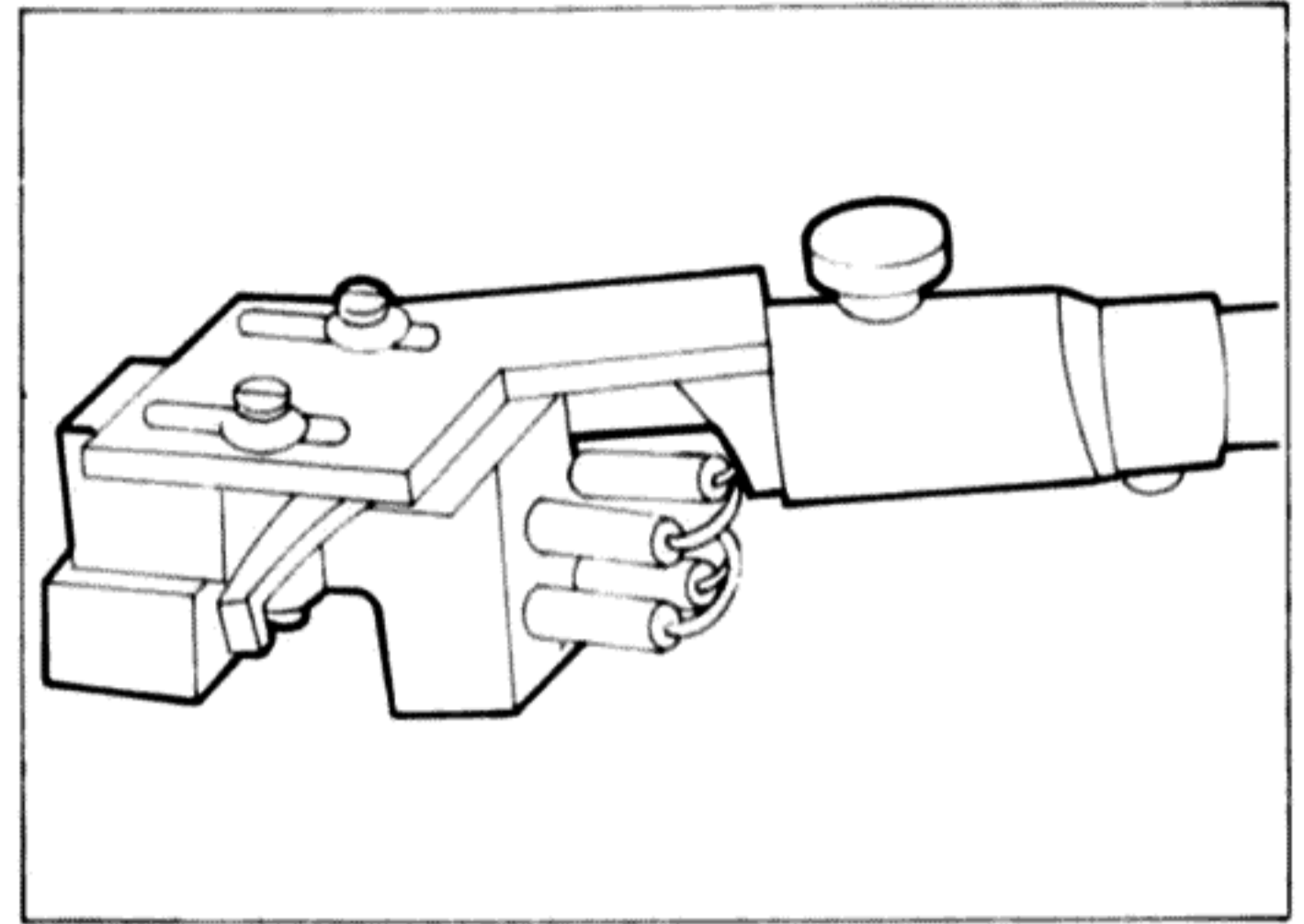

Fig. 3

ASSEMBLY

1. Remove all transportation screws on the turntable platter and the motor board to release the motor suspension. These screws can easily be identified by their red colouring.
2. Gently position the rubber drive belt over the motor capstan shaft (see Figure 2).
3. Place the platter over the central spindle shaft bearing.
4. Lay the turntable mat onto the platter's surface.
5. Attach the counterweight to the tone-arm and rotate it to advance its position. Accurate setting of the counterweight's final position should be left until all assembly is complete.
(Refer to the section headed "Stylus Pressure Adjustment").
6. Fit the headshell to the tone-arm (see Figure 3).
7. Fit the cartridge of your choice to the headshell using the cartridge manufacturer's installation instructions.
8. Attach the clear dust cover at its rear mounted hinges.

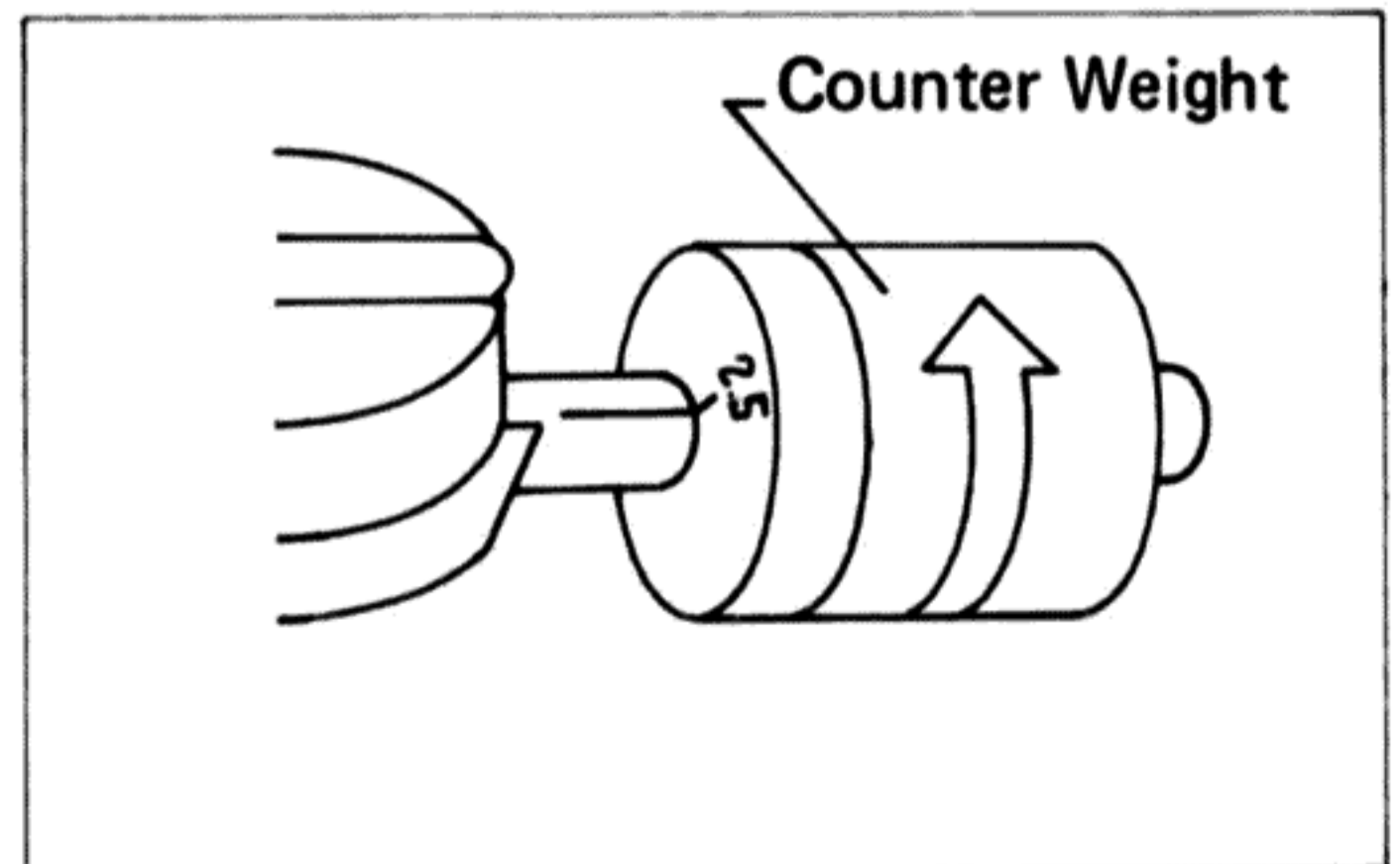
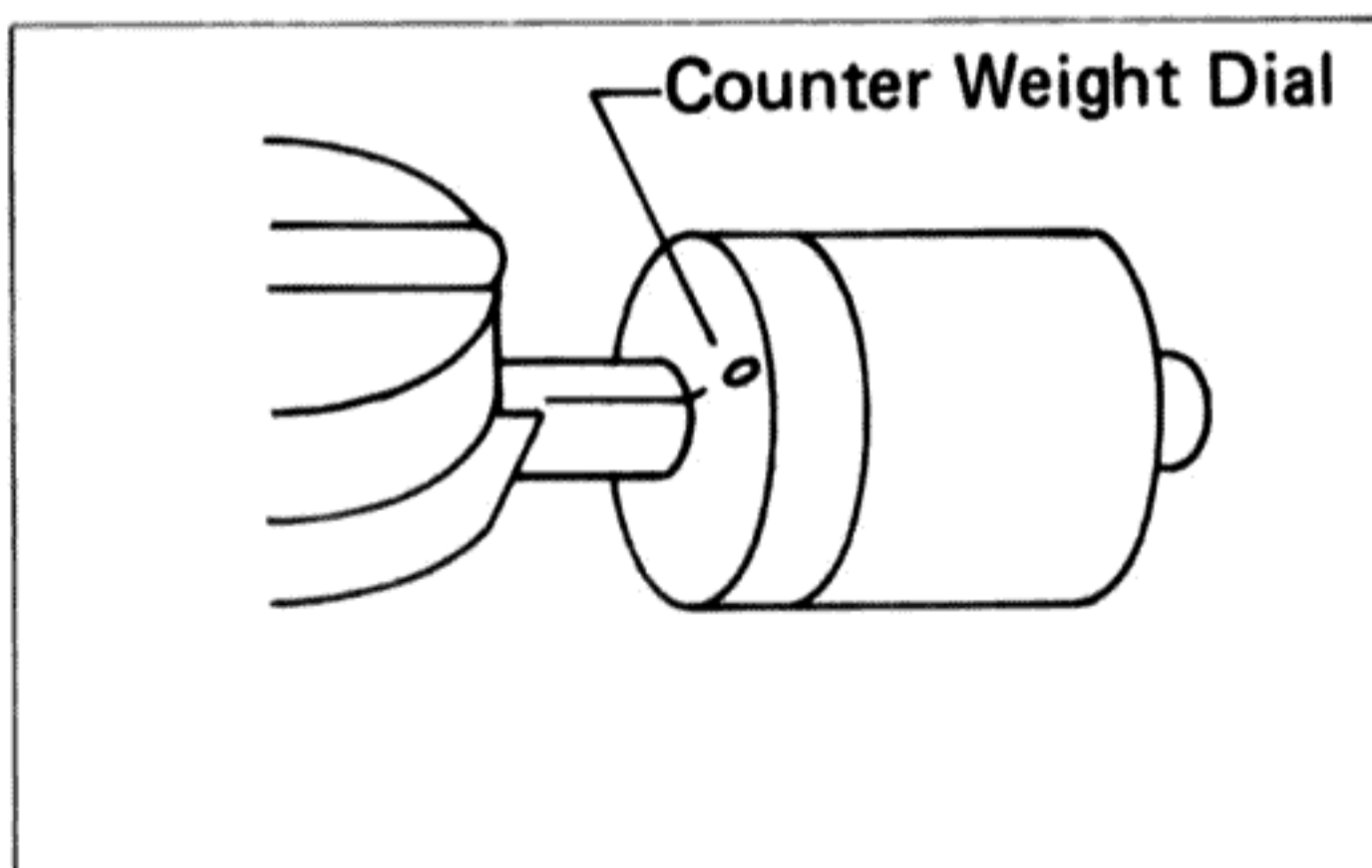

Fig. 4

STYLUS PRESSURE ADJUSTMENT

For best performance, the stylus pressure must be adjusted to the tracking force recommended by the cartridge manufacturer.

Proceed as follows:—

1. Unlock the tone-arm lock and remove the cartridge stylus cover.
2. Start the motor running by moving the tone-arm inwards. Ensure that the cue lever is in the down position so that the tone-arm can move freely. Set the anti-skate control to "O".

NOTE: If the arm lift is initially "sticky", push it down with very gentle finger pressure.

3. Zero balance the tone-arm by rotating the counter weight until the arm is laterally balanced.
4. Turn the counter weight dial ring without turning the counterweight. The "O" position on the dial ring must be opposite the white line marked on the tone-arm. (See Figure 4)
5. Turn the counter weight until the dial ring indicates the cartridge manufacturer's specified stylus pressure.
6. Finally set the anti-skate control to the same value as the stylus tracking force.

CARTRIDGE STYLUS REPLACEMENT

The cartridge stylus life with most diamond styli is approximately 500 hours.

Follow the cartridge manufacturer's instructions for replacement of stylus should this become necessary.

ELECTRICAL CONNECTIONS

1. Connect the output cable to the "PHONO" input terminals of the amplifier, left channel output cable (white plug) to the "L" phono input terminal, and right channel output cable (red plug) to the "R" phono input terminal.
2. Connect the AC power cord to the AC wall outlet.

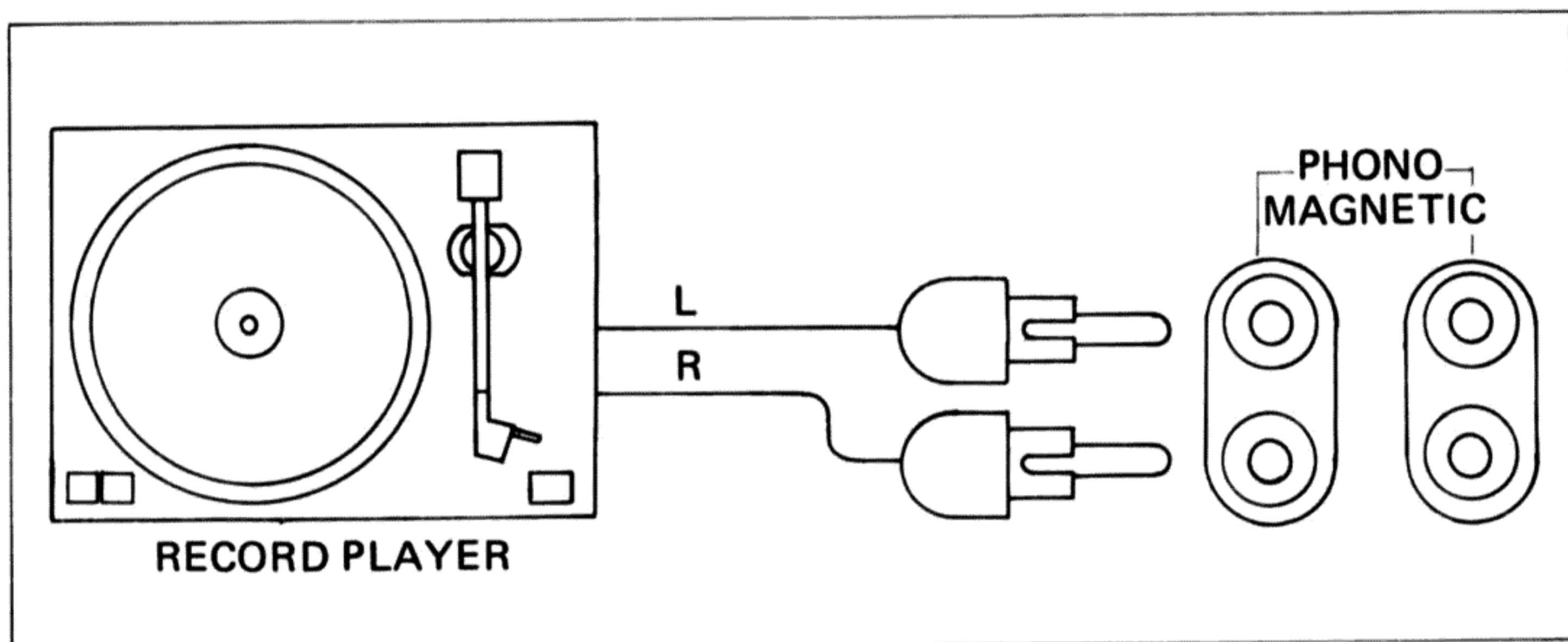

Fig. 5